

**COMPRESSORI
D'ARIA
A PISTONI
PISTON AIR
COMPRESSORS**



NEW
2025 RANGE

Il gruppo FNA

FNA group

Il marchio POWER SYSTEM appartiene al gruppo internazionale FNA, primo costruttore al mondo di compressori a pistoni, indiscusso leader nella produzione di compressori professionali e tra i primi in Europa nel segmento dei compressori industriali a vite, si impone sul mercato grazie ai suoi punti forza: dinamicità, innovazione tecnologica, know how, creatività, marketing integrato, processi produttivi flessibili e un servizio clienti "su misura".

The POWER SYSTEM brand belongs to the international group FNA, the world's leading piston compressors manufacturer, undisputed leader in the production of professional compressors and among the first in Europe in the industrial screw compressor segment, imposes itself on the market thanks to the company strength points: dynamism, technological innovation, know-how, creativity, integrated marketing activities, flexible production processes, and a "tailor-made" customer service.



TORINO
ITALY

Gli stabilimenti di produzione nel mondo

Manufacturing plants worldwide

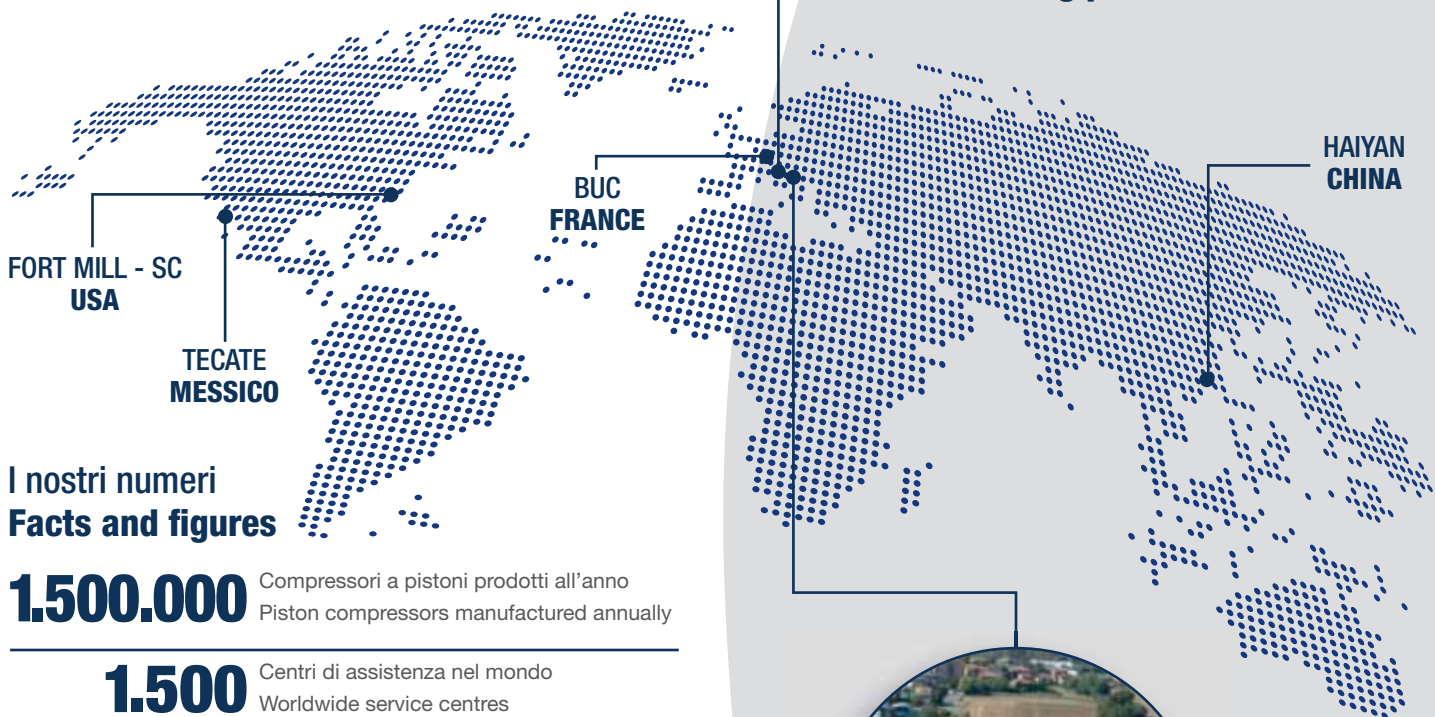

I nostri numeri

Facts and figures

1.500.000 Compressori a pistoni prodotti all'anno
Piston compressors manufactured annually

1.500 Centri di assistenza nel mondo
Worldwide service centres

1.300 Dipendenti
Employees

250 Milioni di € di fatturato
Million € turnover

120 Paesi in cui esporta
The countries we export to

6 Stabilimenti di produzione nel mondo
Production plants worldwide



BOLOGNA
ITALY

Il brand Power System

The Power System brand

I compressori a pistoni POWER SYSTEM rappresentano
“Lo Stato dell’Arte” nei compressori a pistoni professionali.

**POWER SYSTEM piston compressors represent
“The State of the Art” in professional piston compressors.**

Una gamma di compressori a pistoni da 2 a 30 Hp progettati, sviluppati e prodotti dalla A alla Z in Italia, in uno dei più moderni stabilimenti produttivi del settore. Garanzia del controllo di qualità dei materiali/componenti dall'accettazione fino al collaudo del prodotto finale prima della sua spedizione. Durata e affidabilità dei nostri prodotti sono i principali punti di riferimento del nostro Gruppo, e questo da oltre 70 anni.

A range of piston compressors from 2 to 30 Hp designed, developed and produced from A to Z in Italy, in one of the most modern production facilities in the field.

Quality Control assurance from materials/components incoming to the final product testing prior to its shipment.

Endurance and reliability of our products are our Group's primary points of reference, and this since over 70 years.



COME È FATTO UN COMPRESSORE

A

GRUPPO POMPANTE

È la parte principale di un compressore d'aria. All'interno del gruppo pompante, infatti, uno o due pistoni provvedono a prelevare l'aria dall'ambiente esterno ed a comprimerla, immettendola poi nel serbatoio.

AIR COMPRESSOR PUMP

This is the main part of an air compressor. Inside the compressor pump, one or two pistons compress the air taken from the environment and deliver it to the receiver.

B

TUBO DI MANDATA

Collega il gruppo pompante al serbatoio permettendo il passaggio dell'aria compressa dall'uno all'altro.

AIR DELIVERY PIPE

Connects the compressor pump to the receiver, thus, the compressed air is delivered from the compressor pump to the receiver.

C

SERBATOIO

È il recipiente dove viene accumulata l'aria compressa pronta per essere utilizzata. Costruito in lamiera di acciaio di elevato spessore, è sempre collaudato ad una pressione superiore a quella di esercizio. La sua funzione è quella di compensare la differenza fra la quantità di aria prodotta dal gruppo pompante e quella richiesta dall'utente: più il serbatoio è grande meno sono frequenti gli avviamenti del gruppo pompante per riempirlo.

AIR RECEIVER

The vessel which stores the accumulated compressed air ready for use. It is made of extra thick steel and it is always tested to a pressure higher than the working pressure of the compressor. Its function is to compensate the difference between the amount of air produced by the compressor pump and the one required by the user. The use of a larger receiver reduces the number of start-ups required by the compressor.

D

PARACINGHIA / CONVOGLIATORE IN PLASTICA

Protegge da contatti accidentali con le parti in movimento e convoglia l'aria di raffreddamento prodotta dal volano o dalla ventola direttamente sulle parti più calde.

BELT-GUARD / PLASTIC SHROUD

Protects against accidental contact with the moving parts and directs the cooling air produced by the fly wheel or directly by the motor fan towards the areas where the heat is generated.

E

MOTORE ELETTRICO

Trasmette il moto al gruppo pompante direttamente (compressori coassiali) o tramite una cinghia (compressori a cinghia).

ELECTRIC MOTOR

Transmits movement to the air compressor pump either directly (direct driven compressors) or through a belt (belt-driven compressors).

F

MANOMETRI

Un manometro indica la pressione dell'aria all'interno del serbatoio e l'altro la pressione regolata dell'aria in uscita.

GAUGES

One gauge indicates the pressure of the air inside the air receiver and the other one indicates the outlet pressure.

G

PRESSOSTATO

Interrompe il funzionamento del compressore quando la pressione all'interno del serbatoio ha raggiunto il valore prefissato (ad esempio 8 o 10 bar) e provvede al riavvio quando, a causa di un prelievo d'aria dal serbatoio, la pressione scende sotto un valore prestabilito.

PRESSURE SWITCH

Controls the compressor by switching the machine off when the pressure inside the receiver reaches the default value (for example 8 or 10 bar) and restarts the compressor when the compressed air is used and the pressure drops to a pre-set value.

H

RIDUTTORE DI PRESSIONE

Permette di ridurre la pressione dell'aria in uscita dal serbatoio e regolarla in funzione dell'utilizzo.

PRESSURE REDUCER

Allows to reduce the pressure of the air discharged from the receiver and to adjust it according to the application.

I

VALVOLA DI SICUREZZA

La sua apertura evita che la pressione all'interno del serbatoio superi i valori di sicurezza nel caso in cui il pressostato non abbia funzionato correttamente.

SAFETY VALVE

It's opening prevents the pressure inside the receiver from exceeding the safety values in case of the pressure switch failure.

J

VALVOLA DI SPURGO

Consente di eliminare dal serbatoio l'acqua accumulatasi per effetto della condensazione del vapore acqueo contenuto nell'aria compressa.

DRAIN VALVE

Makes it possible to drain all the water that forms in the receiver due to the condensation of the water vapor contained in the compressed air.

THE MAIN PARTS OF A COMPRESSOR

K

RACCORDO USCITA ARIA COMPRESSA

È l'attacco a cui si connette il tubo che porta l'aria compressa all'utensile pneumatico che si vuole impiegare.

COMPRESSED AIR OUTLET CONNECTION

Used to connect the hose that carries the compressed air to the requested air-powered tool.

L

VALVOLA DI NON RITORNO

È una valvola unidirezionale che permette al flusso di aria compressa di passare dal tubo di mandata al serbatoio e ne impedisce il ritorno.

NON RETURN VALVE - CHECK VALVE

The one way valve that allows the air to flow in one direction only, from the compressor pump to the air receiver.

M

FILTRO ASPIRAZIONE ARIA

Filtra l'aria in aspirazione al gruppo pompante del compressore.

AIR INLET FILTER

Filters the air inlet to the pumping unit of the compressor.

N

SILENZIATORE IN ASPIRAZIONE

(standard solo per la gamma SILVER LINE)

AIR INLET SILENCER

(standard only on SILVER LINE)

O

RUOTE PIVOTTANTI CON FRENI

PIVOTTING WHEELS WITH BRAKES

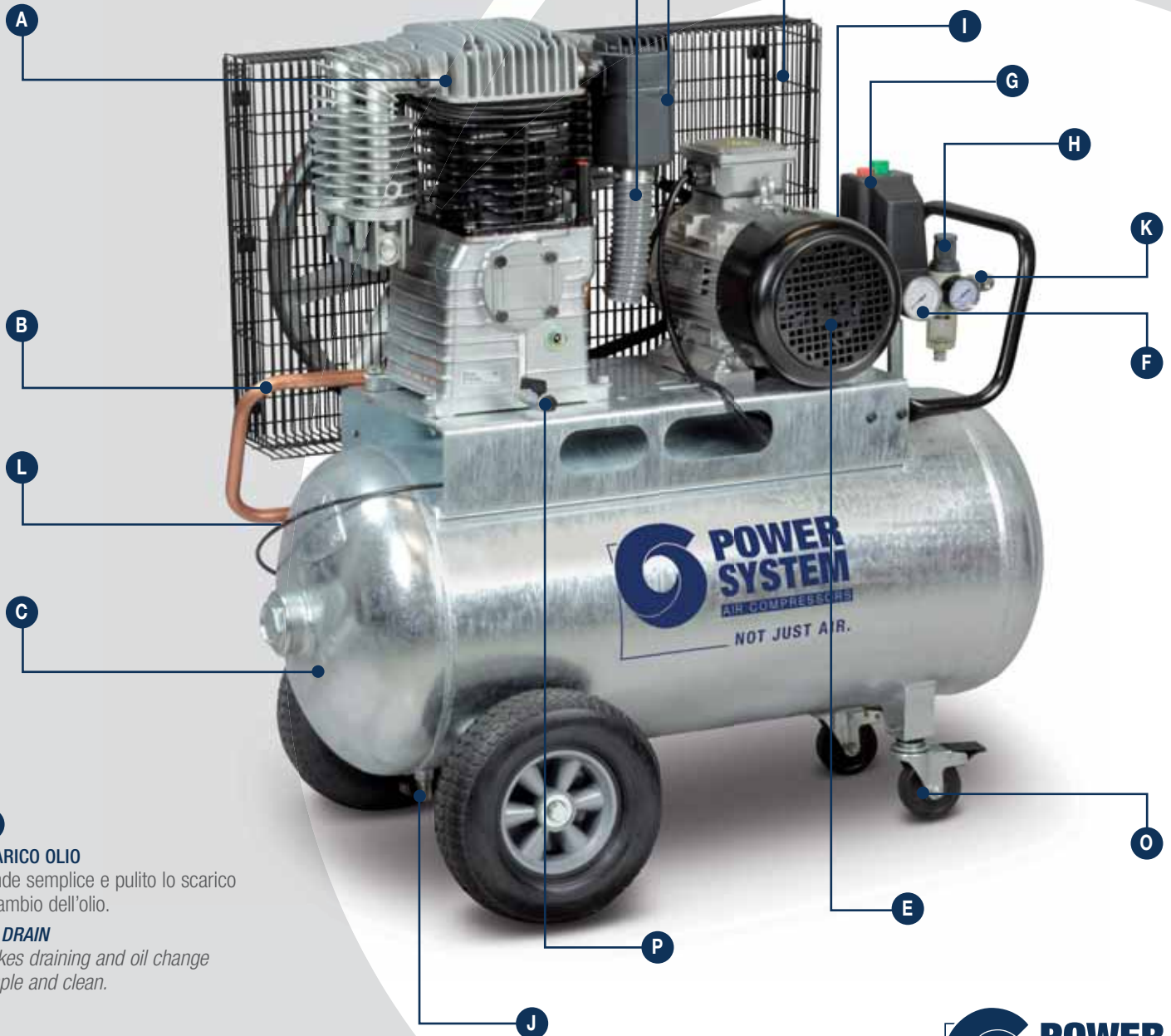

P

SCARICO OLIO

Rende semplice e pulito lo scarico e cambio dell'olio.

OIL DRAIN

Makes draining and oil change simple and clean.

LA GAMMA THE RANGE



7 GRUPPI PUMPS

Gruppi coassiali lubrificati
Coaxial lubricated pumps

Gruppi a cinghia monostadio
Belt driven single-stage pumps

Gruppi a cinghia bistadio
Belt driven two-stage pumps



15 PREMIUM LINE

Compressori coassiali a "V" lubrificati
Coaxial "V" lubricated compressors

Compressori a cinghia monostadio
Belt driven single-stage compressors



19 PLUS LINE

Compressori a cinghia monostadio
Belt driven single-stage compressors

Compressori a cinghia bistadio
Belt driven two-stage compressors



28 SILVER LINE

Compressori a cinghia con serbatoio zincato
Belt driven compressors with galvanized air tank



30 CONTRACTOR LINE

Motocompressori a benzina e diesel
Petrol and diesel engine compressors



33 SILENT LINE

Compressori silenziati a cinghia
Silent belt driven compressors



39 BASIC LINE

Compressori a cinghia monostadio
Belt driven single-stage compressors

GRUPPI PUMPS

Progettati e realizzati per garantire elevate prestazioni, efficienza e affidabilità nel tempo, la gamma dei gruppi Power System si compone delle seguenti famiglie: **gruppi coassiali lubrificati**, costruiti con teste in alluminio pressofuso e cilindri in ghisa per garantire, grazie all'uso di materiali di elevatissima qualità e all'efficace sistema di raffreddamento, un'ottima resistenza all'usura nel tempo; **gruppi monostadio e bistadio**, contraddistinti da:

- intercooler per raffreddamento tra primo e secondo stadio di compressione con conseguente miglioramento in termini di efficienza;
- minore velocità di rotazione che permette una rumorosità contenuta;
- migliori prestazioni grazie alla maggior aria aspirata e al più alto rendimento volumetrico che pone questi compressori ai vertici della loro categoria.

Designed and built to guarantee long-term high level performance, efficiency and reliability, the range of Power System piston pumps covers the following families:

lubricated coaxial piston pumps, built with aluminum cylinder heads and cast-iron cylinders to guarantee excellent wear resistance in time, thanks to the highest quality materials and efficient cooling system; ***single and two-stage piston pumps***, distinguished by:

- *intercooler between first and second compression stage resulting in higher efficiency;*
- *lower rotation speed allowing for more silent operation;*
- *better performance thanks to greater amount of air-intake and higher volumetric yield placing these compressors at the top of their categories.*



GRUPPI PUMPS



I punti di forza dei gruppi bicilindrici a "V" Two cylinders "V" pumps strength points

- Gruppi pompanti potenti e compatti.
 - Potenze da 2 a 3 Hp.
 - Basso numero di giri:
1200/1350 giri/min.
 - Ventilazione forzata.
 - Kit ricambi modulari per tutti i modelli.
- *Powerful and compact pumps.*
 - *Power range from 2 to 3 Hp.*
 - *Low number of revs: 1200/1350 RPM.*
 - *Forced ventilation.*
 - *Modular spare parts kit for all models.*

HD65DV



CILINDRI
In ghisa, progettati per un ottimale smaltimento del calore.

ALBERO A GOMITO
In ghisa, sferoidale, progettato per minimizzare le vibrazioni del manovellismo e massimizzare la vita della macchina.

CYLINDERS
In cast iron, designed for optimal heat dissipation.

CRANKSHAFT
Cast iron, spheroidal, designed to minimize crankshaft stroke + conrod mechanism vibrations and maximize the life of the machine.



CARTER
Sovradimensionato per garantire un'eccellente lubrificazione agli organi meccanici in movimento.

CRANKCASE
Oversized to ensure an excellent lubrication of the internal mechanisms.



PIASTRA VALVOLE
Progettata in modo da garantire elevata rigidità e un migliore scambio termico. Con lamelle in acciaio inox ad alta resistenza, ideali per servizio continuo.

VALVES PLATE
Designed to ensure high stiffness and better heat exchange. Stainless steel reeds with high strength, ideal for continuous service.

Nome Name	Codice Code	Cilindri Cylinder	Stadi Stages	Volano Flywheel	Filtro Filter	Collettore After cooler	Aria aspirata Air displac.		Potenza Power		N° Giri RPM	Volt/Hz	Press. Max Max press.	
							l/min.	CFM	Hp	kW			bar	PSI

Gruppi coassiali lubrificati | Coaxial lubricated pumps

HD65DV	R_018304	2	1	–	Rotondo/Round	YES	305	10,7	2,5	1,8	1350	230/50	10	145
HD65DVT	R_018404	2	1	–	Rotondo/Round	YES	305	10,7	2,5	1,8	1350	400/50	10	145

GRUPPI - PUMPS

Gruppi coassiali lubrificati - Gruppi a cinghia monostadio

Coaxial lubricated pumps - Belt driven single-stage pumps

HD60CV3



COLLETORE DI USCITA ARIA

Collettore di uscita dell'aria di dimensioni uniche nella sua categoria, garantisce un eccellente raffreddamento dell'aria.

AIR AFTERCOOLER

Unique in its category size, guarantees excellent air cooling.



MOTOPROTEETTORE

Il motore elettrico è protetto con moto protettore termico a riarmo manuale.

MOTOR PROTECTOR

The electric motor is protected with a thermal motor protector with manual reset.



TESTA

Basse temperature di esercizio ottenute mediante l'impiego di teste in alluminio con ampie alettature.

HEAD

Efficient cooling using aluminum heads with large cooling fins.



VOLANO

Il disegno delle pale è stato realizzato per garantire una efficace ventilazione delle parti calde del gruppo pompante.

FLYWHEELS

Flywheel featuring special blades design to ensure effective ventilation of the hot parts of the pumping unit.



VALVOLA DI PARTENZA A VUOTO

Consente al compressore di partire anche in condizioni estremamente sfavorevoli (basse temperature, bassa tensione di alimentazione).

UNLOADING START VALVE

Allows the compressor start-up even in extremely severe conditions (low temperatures, low power supply voltage).

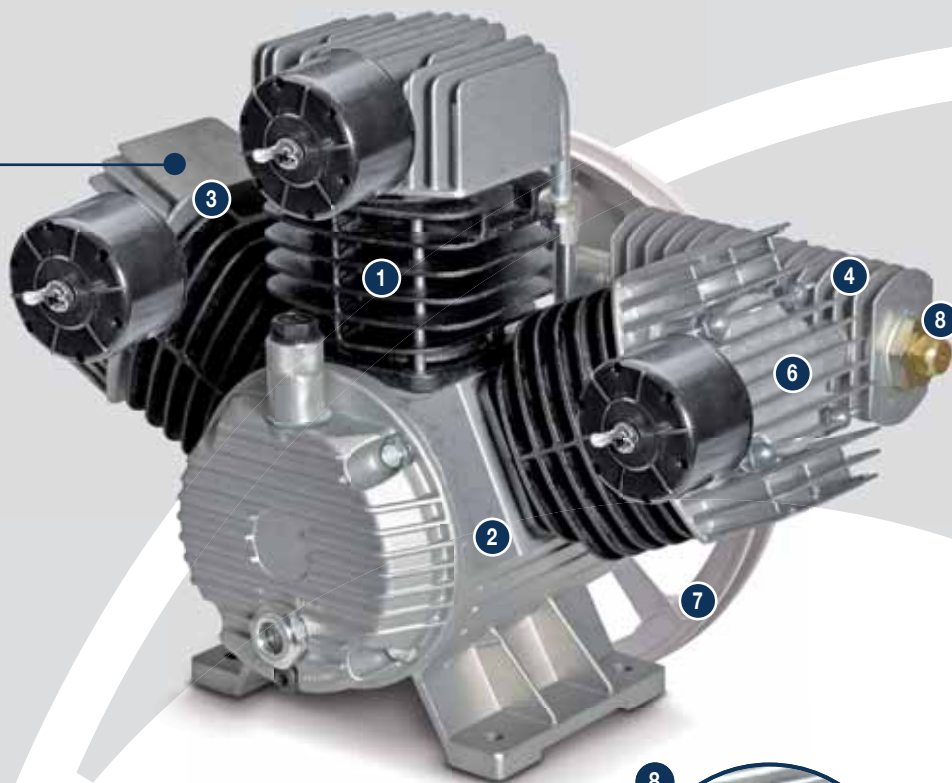

Nome Name	Codice Code	Cilindri Cylinder	Stadi Stages	Volano Flywheel	Filtro Filter	Collettore After cooler	Aria aspirata Air displac.		Potenza Power		N° Giri RPM	Volt/Hz	Press. Max Max press.	
							l/min.	CFM	Hp	kW			bar	PSI

Gruppi a cinghia monostadio | Belt driven single-stage pumps

HD60CV	R_018504	2	1	-	Rotondo/Round	YES	330	11,6	2	1,5	1200	230/50	10	145
HD60CV3	R_018505	3	1	-	Rotondo/Round	YES	440	15,5	3	2,2	1200	230/50	10	145

GRUPPI PS - I punti di forza PS PUMPS - Strength points

GRUPPI POMPANTI A CINGHIA MONOSTADIO E BISTADIO

- Adatti ad un servizio gravoso e continuo
- Potenti ed affidabili
- Elevate prestazioni
- Lunga durata
- Basse vibrazioni
- Basse velocità di rotazione

BELT DRIVEN SINGLE AND TWO-STAGE PUMPS

- Heavy Duty service
- Strong and Reliable
- High performances
- Long life
- Low vibrations
- Low speed



FILTRO ARIA IN ASPIRAZIONE

- Sistema a labirinto per ridurre il rumore.
- Elevata superficie filtrante.
- Lunga durata.

AIR INLET FILTER

- Labyrinth system to reduce noise.
- Large dust filter surface.
- Long life time.



PIASTRA VALVOLE

- Piastra in ghisa: robusta, affidabile, a lunga durata.
- Camere di passaggio aria sovradimensionate per una ideale temperatura di lavorazione e per ottenere elevate prestazioni.

VALVES PLATE

- Cast iron, strong, reliable, longlife.
- Oversized air passage chambre for better temperature and high performances.



GUARNIZIONI PIASTRA VALVOLE

- In acciaio inox con riporto di elastomeri: garantiscono una perfetta tenuta e una lunga durata nelle condizioni d'uso più severe.

VALVES PLATE GASKET

- In stainless steel with carryover of elastomers: assuring perfect seal and long life in the harshest working conditions.



CARTER

- Grande capienza di olio per una lunga autonomia.
- Verniciatura interna con resina che impedisce le perdite d'olio.
- Assenza di vibrazioni: fusione in alluminio con grandi spessori.

CRANKCASE

- Large oil capacity for a long autonomy.
- Internal painting with resin preventing oil losses.
- No vibrations: generous aluminum thickness casting.



TESTA

- In alluminio pressofuso per una migliore dissipazione di calore.
- Ampie alettature per il massimo raffreddamento.

HEAD

- *Alu die casting for a better dissipation of heat.*
- *Large fins for maximum cooling.*



COLLETTORI

- In alluminio pressofuso per una migliore dissipazione di calore.
- Ampie alettature per il massimo raffreddamento.

AFTERCoolER

- *Alu die casting for a better dissipation of heat.*
- *Large fins for maximum cooling.*

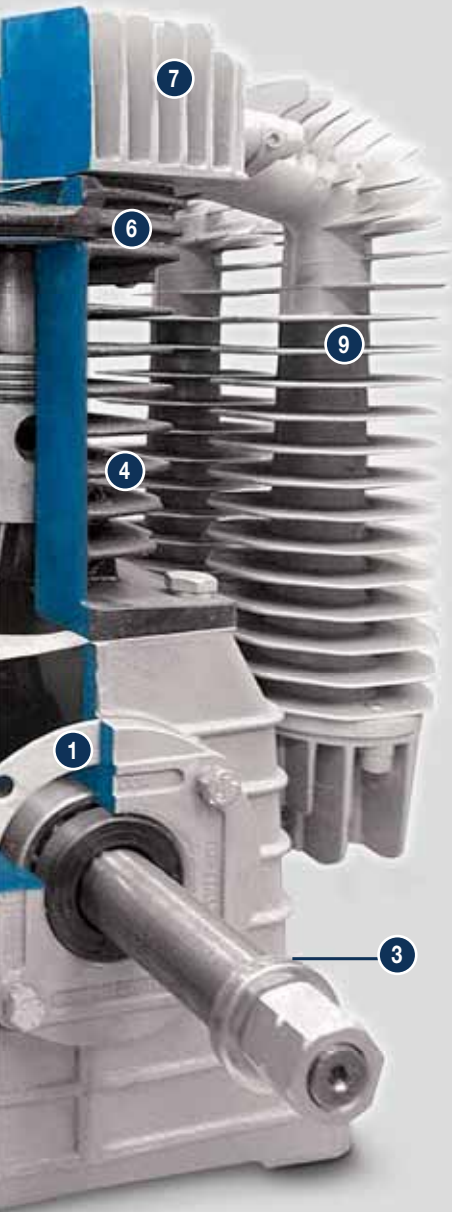

ALBERO A GOMITO E BIELLE

- Albero a gomito bilanciato elettronicamente: nessuna vibrazione.
- Bielle dotate di bronzine con materiale a basso attrito assicurano alta efficienza e riduzione dell'usura.

CRANKSHAFT AND CONNECTING ROD

- *Crankshaft balanced with electronic equipment: no vibration.*
- *Con-rod's bushes made with low friction material assuring high efficiency and reduced wear.*

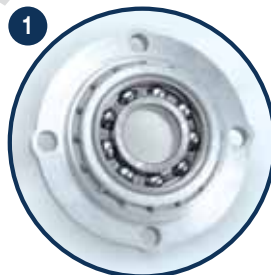

CUSCINETTI

Cuscinetti volventi di alta qualità sono la base per garantire un servizio continuo in tutte le condizioni di lavoro.

BEARINGS

High quality ball bearings are the basis for ensuring a continuous service in any working conditions.



CILINDRI

- In ghisa: affidabili, resistenti.
- Speciali lavorazioni assicurano un basso consumo di olio.

CYLINDERS

- *In cast iron: strong, reliable, heavy duty.*
- *Special machining to assure low oil consumption.*



VOLANI

Il profilo delle pale del volano è progettato per assicurare un elevato raffreddamento.

FLYWHEELS

The flywheel blades profile is designed to ensure high cooling performances.

GRUPPI - PUMPS

Gruppi a cinghia monostadio

Belt driven single-stage pumps

PS2800



PS3800B



PS11



PS17



PS18C



PS236



Nome Name	Codice Code	Cilindri Cylinder	Stadi Stages	Volano Flywheel	Filtro Filter	Collettore After cooler	Aria aspirata Air displac.		Potenza Power		N° Giri RPM	Press. Max Max press.	
		n.	n.	diam./mat.			tipo/type	l/min.	CFM	Hp		kW	bar
PS2800	2800000	2	1	280-AL	Rettangolare/Square	NO	255	9	2	1,5	1250	10	145
PS2800B	280000B	2	1	280-AL	Rettangolare/Square	YES	330	11,6	3	2,2	1570	10	145
PS3800B	370000B	2	1	350-AL	Rettangolare/Square	YES	480	16,9	4	3	1400	10	145
PS11	SC0000A	2	1	280-AL	Rotondo/Round	NO	260	9,2	2	1,5	1180	10	145
PS17	SD0000A	2	1	320-AL	Esagonale/Hexagonal	NO	400	14,1	3	2,2	1250	10	145
PS18C	SE0000B	2	1	320-AL	Esagonale/Hexagonal	YES	539	19	4	3	1400	10	145
PS236	HHP0000	2	1	-	Rotondo/Round	YES	235	8,3	4	3	3400	10	145

GRUPPI - PUMPS

GRUPPI PS - Gruppi a cinghia bistadio

PS PUMPS - Belt driven two-stage pumps



PS25



PS28



PS30



PS50



Nome Name	Codice Code	Cilindri Cylinder	Stadi Stages	Volano Flywheel	Filtro Filter	Collettore After cooler	Aria aspirata Air displac.		Potenza Power		N° Giri RPM	Press. Max Max press.	
		n.	n.	diam./mat.	tipo/type		l/min.	CFM	Hp	kW		bar	PSI
PS25	SG0000A	2	2	385-AL	Esagonale/Hexagonal	YES	495	17,4	4	3	1200	11	160
PS28	SH0000A	2	2	385-AL	Esagonale/Hexagonal	YES	662	23,4	5,5	4	1290	11	160
PS30	SL0000A	2	2	400-GH	Esagonale/Hexagonal	YES	872	30,7	7,5	5,5	1200	11	160
PS50	SM0000A	2	2	550-GH	Esagonale/Hexagonal	YES	1074	37,8	10	7,5	1000	11	160

GRUPPI - PUMPS

GRUPPI PS | Gruppi a cinghia bistadio

PS PUMPS | Belt driven two-stage pumps



PS60



PS100

Nome Name	Codice Code	Cilindri Cylinder	Stadi Stages	Volano Flywheel	Filtro Filter	Collettore After cooler	Aria aspirata Air displac.		Potenza Power		N° Giri RPM	Press. Max Max press.	
		n.	n.	diam./mat.			l/min.	CFM	Hp	kW		bar	PSI
PS60	SN0000A	4V	2	550-GH	Rotondo su gomito 45° Round up elbow 45°	YES	1745	61,6	15	11	1200	11	160
PS100	SP0000A	4V	2	550-GH	Rotondo su gomito 45° Round up elbow 45°	YES	2148	75,8	20	15	1000	11	160

PREMIUM LINE

Compressori coassiali a "V" lubrificati
Compressori a cinghia monostadio
Coaxial "V" lubricated compressors
Belt driven single-stage compressors

La Premium Line comprende compressori con potenze da 2 a 3 Hp e serbatoi da 50 a 200 litri, sintesi della pluriennale esperienza nel settore dell'aria compressa professionale. Queste macchine sono progettate e realizzate all'interno degli stabilimenti italiani del nostro Gruppo e sono gli strumenti ideali di lavoro per il professionista, l'artigiano e la piccola industria.

Questa gamma si compone delle seguenti categorie:

- **compressori coassiali a "V" lubrificati** che montano gruppi pompanti realizzati in alluminio con cilindro in ghisa e garantiscono una grande portata d'aria.
- **compressori a cinghia monostadio**, che si distinguono sul mercato per: intercooler per raffreddamento tra primo e secondo stadio di compressione con conseguente miglioramento in termini di efficienza; minore velocità di rotazione che permette una rumorosità contenuta.

Premium Line covers compressors with output power between 2 and 3 Hp and 50 to 200 liters tanks. It is the result of a long experience in the professional and industrial air compression sector.

These machines are designed and manufactured in the Italian production facilities of the Group and are the ideal tools for the professional work of the artisan and small-scale industry.

This range consists of the following categories:

- **coaxial lubricated "V" belt compressor** mounting aluminum compressor pumps with cast iron cylinder guaranteeing a large air supply.
- **belt driven single-stage compressors.** The features that make this range unique on the market are: air intercooler between the first and second stage with consequent improvement in terms of efficiency; slower rotation speed minimising sound levels.



PREMIUM LINE

Compressori coassiali a "V" lubrificati
Coaxial "V" lubricated compressors



HD65DV/50 CM2,5



HD65DV/100 CM2,5



Nome Name	Codice Code	Gruppo Pump	Serbatoio Tank		Potenza Power		Cilindri Cylinder		Press. Max Max press.		N° Giri RPM	Aria aspirata Air displacement		Volt/Hz	Peso lordo Gross weight		Dimensioni imballo Box dimensions		Codice a barre Ean code
			L	Hp	kW	n.	bar	PSI	l/min.	CFM		kg	Lbs		LxPxH	WxDxH			
HD65DV/50 CM2,5	RVDC4G4PWS022	HD65DV	50	2,5	1,8	2	10	145	1350	305	10,7	230/50	65	143,3	820x390x750	8016738758917			
HD65DV/50 CT2,5	RVDC4G1PWS023	HD65DV	50	2,5	1,8	2	10	145	1350	305	10,7	400/50	65	143,3	820x390x750	8016738758924			
HD65DV/100 CM2,5	RVFC4G4PWS024	HD65DV	100	2,5	1,8	2	10	145	1350	305	10,7	230/50	78	172,0	1025x390x820	8016738758931			
HD65DV/100 CT2,5	RVFC4G1PWS025	HD65DV	100	2,5	1,8	2	10	145	1350	305	10,7	400/50	78	172,0	1025x390x820	8016738758948			
HD65DV/150 CM2,5	RVHC4G4PWS026	HD65DV	150	2,5	1,8	2	10	145	1350	305	10,7	230/50	98	216,1	1310x410x960	8016738758955			
HD65DV/150 CT2,5	RVHC4G1PWS027	HD65DV	150	2,5	1,8	2	10	145	1350	305	10,7	400/50	98	216,1	1310x410x960	8016738758962			

PREMIUM LINE

Compressori coassiali a "V" lubrificati
Coaxial "V" lubricated compressors

HD65DV/24 PCM2,5



HD65DV/9+9 CM2,5

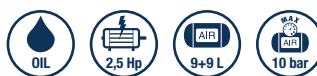

Nome Name	Codice Code	Gruppo Pump	Serbatoio Tank		Potenza Power		Cilindri Cylinder		Press. Max Max press.		N° Giri RPM	Aria aspirata Air displacement		Volt/Hz	Peso lordo Gross weight		Dimensioni imballo Box dimensions	Codice a barre Ean code
			L	Hp	kW	n.	bar	PSI	l/min.	CFM		kg	Lbs		LxPxAx WxDxH			
HD65DV/24 PCM 2,5	RVXV4G4PWS028	HD65DV	24	2,5	1,8	2	10	145	1350	305	10,7	230/50	58	127,9	640x530x780	8016738758979		
HD65DV/24 PCT2,5	RVXV4G1PWS029	HD65DV	24	2,5	1,8	2	10	145	1350	305	10,7	400/50	58	127,9	640x530x780	8016738758986		
HD65DV/9+9 CM2,5	RVBW4G4PWS032	HD65DV	9+9	2,5	1,8	2	10	145	1350	305	10,7	230/50	51	112,4	630x630x580	8016738759013		
HD65DV/9+9 CT2,5	RVBW4G1PWS033	HD65DV	9+9	2,5	1,8	2	10	145	1350	305	10,7	400/50	51	112,4	630x630x580	8016738759020		

PREMIUM LINE

Compressori a cinghia monostadio
Belt driven single-stage compressors



HD60CV/50 CM2



HD60CV3/100 CT3



Nome Name	Codice Code	Gruppo Pump	Serbatoio Tank		Potenza Power		Cilindri Cylinder	Press. Max Max press.		N° Giri RPM	Aria aspirata Air displacement		Volt/Hz	Peso lordo Gross weight		Dimensioni imballo Box dimensions	Codice a barre Ean code
			L	Hp	kW	n.		bar	PSI		l/min.	CFM		kg	Lbs		
HD60CV/50 CM2	RBDC404PWS034	HD60CV	50	2	1,5	2	10	145	1200	330	11,6	230/50	65	143,3	840x380x780	8016738759037	
HD60CV/50 CT2	RBDC441PWS035	HD60CV	50	2	1,5	2	10	145	1200	330	11,6	400/50	65	143,3	840x380x780	8016738759044	
HD60CV3/50 CM3	RWDC504PWS036	HD60CV3	50	3	2,2	3	10	145	1200	440	15,5	230/50	73	160,9	840x380x780	8016738759051	
HD60CV3/50 CT3	RWDC541PWS037	HD60CV3	50	3	2,2	3	10	145	1200	440	15,5	400/50	73	160,9	840x380x780	8016738759068	
HD60CV/100 CM2	RBFC404PWS038	HD60CV	100	2	1,5	2	10	145	1200	330	11,6	230/50	76	167,5	1010x390x790	8016738759075	
HD60CV/100 CT2	RBFC441PWS039	HD60CV	100	2	1,5	2	10	145	1200	330	11,6	400/50	76	167,5	1010x390x790	8016738759082	
HD60CV3/100 CM3	RWFC504PWS040	HD60CV3	100	3	2,2	3	10	145	1200	440	15,5	230/50	79	174,2	1010x390x790	8016738759099	
HD60CV3/100 CT3	RWFC541PWS041	HD60CV3	100	3	2,2	3	10	145	1200	440	15,5	400/50	79	174,2	1010x390x790	8016738759105	
HD60CV/150 CM2	RBHC404PWS042	HD60CV	150	2	1,5	2	10	145	1200	330	11,6	230/50	99	218,3	1310x430x1030	8016738759112	
HD60CV/150 CT2	RBHC441FWS043	HD60CV	150	2	1,5	2	10	145	1200	330	11,6	400/50	99	218,3	1310x430x1030	8016738759129	
HD60CV3/150 CM3	RWHC504PWS044	HD60CV3	150	3	2,2	3	10	145	1200	440	15,5	230/50	107	235,9	1310x430x1030	8016738759136	
HD60CV3/150 CT3	RWHC541PWS045	HD60CV3	150	3	2,2	3	10	145	1200	440	15,5	400/50	107	235,9	1310x430x1030	8016738759143	
HD60CV3/200 CM3	RWLC504PWS046	HD60CV3	200	3	2,2	3	10	145	1200	440	15,5	230/50	118	260,1	1435x475x1125	8016738759150	
HD60CV3/200 CT3	RWLC541PWS047	HD60CV3	200	3	2,2	3	10	145	1200	440	15,5	400/50	118	260,1	1435x475x1125	8016738759167	

PLUS LINE

Compressori a cinghia monostadio e bistadio
Compressori serie Twin Tank - Verticali - Tandem

Belt driven single and two-stage compressors
Twin Tank - Vertical - Tandem piston compressors

La Plus Line è la gamma top della produzione Power System che comprende compressori a cinghia con potenze da 3 a 30 Hp e serbatoi da 34 a 900 litri. Sono prodotti unici ed inimitabili, macchine professionali di altissima qualità che si contraddistinguono per la loro totale affidabilità, l'uso di materiali all'avanguardia e la cura industriale della loro realizzazione.

I pregi che distinguono e rendono unica sul mercato la gamma sono:

- intercooler per raffreddamento tra primo e secondo stadio di compressione con conseguente miglioramento in termini di efficienza;
- minore velocità di rotazione che permette una rumorosità contenuta;
- migliori prestazioni grazie alla maggior aria aspirata e al più alto rendimento volumetrico.

Plus Line is the top of range of the Power System production covering belt driven compressors with output power between 3 and 30 Hp and 34 to 900 liters tanks.

Unique and inimitable products, professional machines of the highest quality standing out for their total reliability, built with the latest production technology and Quality Control System.

The features making this range unique on the market:

- *air intercooler between the first and second stage with consequent improvement in terms of efficiency;*
- *slower rotation speed minimising sound levels;*
- *better performances thanks to the higher air intake and higher volumetric efficiency.*



PLUS LINE

Compressori a cinghia monostadio e bistadio
Belt driven single and two-stage compressors



PS17/200 CM3



PS28/90 CT5,5

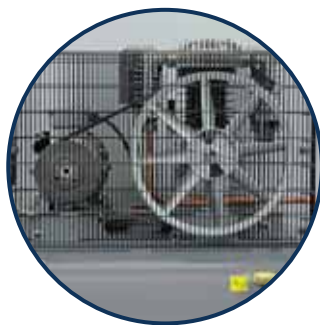

Nome Name	Codice Code	Gruppo Pump	Serbatoio Tank		Potenza Power		Cilindri Cylinder		Press. Max Max press.		N° Giri RPM	Aria aspirata Air displacement		Volt/Hz	Peso lordo Gross weight		Dimensioni imballo Box dimensions	Codice a barre Ean code
			L	Hp	kW	n.	bar	PSI	l/min.	CFM		kg	Lbs		LxPxX WxDxH			
Compressori a cinghia monostadio Belt driven single-stage compressors																		
PS17/200 CM3	SZLC504PWS108	PS17	200	3	2,2	2	10	145	1250	400	14,1	230/50	116	255,7	1435x470x1125	8016738792935		
PS17/200 CT3	SZLC541PWS109	PS17	200	3	2,2	2	10	145	1250	400	14,1	400/50	116	255,7	1435x470x1125	8016738792942		
Compressori a cinghia bistadio Belt driven two-stage compressors																		
PS25/90 CT4	SGGC601PWS225	PS25	90	4	3	2	11	160	1200	495	17,4	400/50	88	194	1010x510x970	8016738794762		
PS28/90 CT5,5	SHGC701PWS226	PS28	90	5,5	4	2	11	160	1290	662	23,3	400/50	96	211,6	1010x510x970	8016738794779		



NOT JUST AIR.

PLUS LINE

Compressori a cinghia bistadio
Belt driven two-stage compressors



PS28/270 CT5,5



Avviamento stella-triangolo.
Star-delta starter.

Nome Name	Codice Code	Gruppo Pump	Serbatoio Tank	Potenza Power		Cilindri Cylinder	Press. Max Max press.		N° Giri RPM	Aria aspirata Air displacement		Volt/Hz	Peso lordo Gross weight		Dimensioni imballo Box dimensions	Codice a barre Ean code
			L	Hp	kW		bar	PSI		l/min.	CFM		kg	Lbs		
PS25/200 CT4	SGLC601PWS048	PS25	200	4	3	2	11	160	1200	495	17,4	400/50	123	271,2	1435x470x1240	8016738759174
PS25/200 FT4	SGLN601PWS049	PS25	200	4	3	2	11	160	1200	495	17,4	400/50	123	271,2	1435x470x1240	8016738759181
PS25/200 FT5,5	SGLN701PWS110	PS25	200	5,5	4	2	11	160	1184	612	21,6	400/50	128	282,2	1435x470x1240	8016738792959
PS25/270 CT4	SGNC601PWS111	PS25	270	4	3	2	11	160	1200	495	17,4	400/50	143	315,3	1640x560x1190	8016738792966
PS25/270 FT4	SGNN601PWS112	PS25	270	4	3	2	11	160	1200	495	17,4	400/50	143	315,3	1640x560x1190	8016738792973
PS25/500 FT5,5	SGTN701PWS113	PS25	500	5,5	4	2	11	160	1184	612	21,6	400/50	218	480,6	2010x650x1330	8016738792980
PS28/270 CT5,5	SHNC701PWS114	PS28	270	5,5	4	2	11	160	1290	662	23,3	400/50	153	337,3	1640x560x1330	8016738792997
PS28/270 FT5,5	SHNN701PWS115	PS28	270	5,5	4	2	11	160	1290	662	23,3	400/50	153	337,3	1640x560x1330	8016738793000
PS28/270 FT5,5 SD	SHNN705PWS116	PS28	270	5,5	4	2	11	160	1290	662	23,3	400/50	159	350,5	1640x560x1330	8016738793017
PS28/500 CT5,5	SHTC701PWS117	PS28	500	5,5	4	2	11	160	1290	662	23,3	400/50	218	480,6	2010x650x1330	8016738793024
PS28/500 FT5,5	SHTN701PWS118	PS28	500	5,5	4	2	11	160	1290	662	23,3	400/50	218	480,6	2010x650x1330	8016738793031
PS28/500 FT5,5 SD	SHTN705PWS119	PS28	500	5,5	4	2	11	160	1290	662	23,3	400/50	224	493,8	2010x650x1330	8016738793048

PLUS LINE

Compressori a cinghia bistadio

Belt driven two-stage compressors

PS30/270 CT5,5



Avviamento stella-triangolo.
Star-delta starter.



Nome Name	Codice Code	Gruppo Pump	Serbatoio Tank		Potenza Power		Cilindri Cylinder		Press. Max Max press.		N° Giri RPM	Aria aspirata Air displacement		Volt/Hz	Peso lordo Gross weight		Dimensioni imballo Box dimensions		Codice a barre Ean code
			L	Hp	kW	n.	bar	PSI	l/min.	CFM		kg	Lbs		LxPxA	WxDxH			
PS30/270 CT5,5	SLNC701PWS050	PS30	270	5,5	4	2	11	160	1000	727	25,6	400/50	164	361,6	1640x560x1330	8016738759198			
PS30/270 FT5,5	SLNN701PWS120	PS30	270	5,5	4	2	11	160	1000	727	25,6	400/50	164	361,6	1640x560x1330	8016738793055			
PS30/270 FT5,5 SD	SLNN705PWS121	PS30	270	5,5	4	2	11	160	1000	727	25,6	400/50	170	374,8	1640x560x1330	8016738793062			
PS30/270 CT7,5	SLNC801PWS051	PS30	270	7,5	5,5	2	11	160	1200	872	30,7	400/50	171	377,0	1640x560x1330	8016738759204			
PS30/270 CT7,5 SD	SLNC805PWS122	PS30	270	7,5	5,5	2	11	160	1200	872	30,7	400/50	178	392,4	1640x560x1330	8016738793079			
PS30/270 FT7,5	SLNN801PWS123	PS30	270	7,5	5,5	2	11	160	1200	872	30,7	400/50	171	377,0	1640x560x1330	8016738793086			
PS30/270 FT7,5 SD	SLNN805PWS124	PS30	270	7,5	5,5	2	11	160	1200	872	30,7	400/50	178	392,4	1640x560x1330	8016738793093			
PS50/270 FT10	SMNN901PWS102	PS50	270	10	7,5	2	11	160	1000	1074	37,8	400/50	208	458,6	1600x700x1330	8016738791648			
PS30/500 CT7,5	SLTC801PWS125	PS30	500	7,5	5,5	2	11	160	1200	872	30,7	400/50	240	529,1	2010x650x1330	8016738793109			
PS30/500 FT7,5	SLTN801PWS052	PS30	500	7,5	5,5	2	11	160	1200	872	30,7	400/50	240	529,1	2010x650x1330	8016738759211			
PS30/500 FT7,5 SD	SLTN805PWS053	PS30	500	7,5	5,5	2	11	160	1200	872	30,7	400/50	250	551,2	2010x650x1330	8016738759228			

PLUS LINE

Compressori a cinghia bistadio
Belt driven two-stage compressors



PS50/500 FT10



Avviamento stella-triangolo.
Star-delta starter.

Nome Name	Codice Code	Gruppo Pump	Serbatoio Tank		Potenza Power		Cilindri Cylinder		Press. Max Max press.		N° Giri RPM	Aria aspirata Air displacement		Volt/Hz	Peso lordo Gross weight		Dimensioni imballo Box dimensions	Codice a barre Ean code
			L	Hp	kW	n.	bar	PSI	l/min.	CFM		kg	Lbs		LxPxH	WxDxH		
PS50/500 FT10	SMTN901PWS054	PS50	500	10	7,5	2	11	160	1000	1074	37,8	400/50	285	628,3	2270x860x1660	8016738759235		
PS50/500 FT10 SD	SMTN905PWS055	PS50	500	10	7,5	2	11	160	1000	1074	37,8	400/50	295	650,4	2270x860x1660	8016738759242		
Alta pressione High pressure																		
PS30/500 AP FT5,5	SLTN701PWS126	PS30	500	5,5	4	2	14	203	785	570	20,1	400/50	265	584,2	2010x650x1330	8016738793116		
PS30/500 AP FT5,5 SD	SLTN705PWS127	PS30	500	5,5	4	2	14	203	785	570	20,1	400/50	275	606,3	2010x650x1330	8016738793123		
PS30/500 AP FT7,5	SLTN801PWS128	PS30	500	7,5	5,5	2	14	203	900	660	23,2	400/50	271	597,4	2010x650x1330	8016738793130		
PS30/500 AP FT7,5 SD	SLTN805PWS129	PS30	500	7,5	5,5	2	14	203	900	660	23,2	400/50	283	623,9	2010x650x1330	8016738793147		
PS50/500 AP FT7,5 SD	SMTN805PWS130	PS50	500	7,5	5,5	2	14	203	750	805	28,4	400/50	288	634,9	2270x860x1660	8016738793154		
PS50/500 AP FT10	SMTN901PWS131	PS50	500	10	7,5	2	14	203	800	857	30,2	400/50	323	712,1	2270x860x1660	8016738793161		
PS50/500 AP FT10 SD	SMTN905PWS132	PS50	500	10	7,5	2	14	203	800	857	30,2	400/50	333	734,1	2270x860x1660	8016738793178		

PLUS LINE

Compressori a cinghia bistadio

Belt driven two-stage compressors

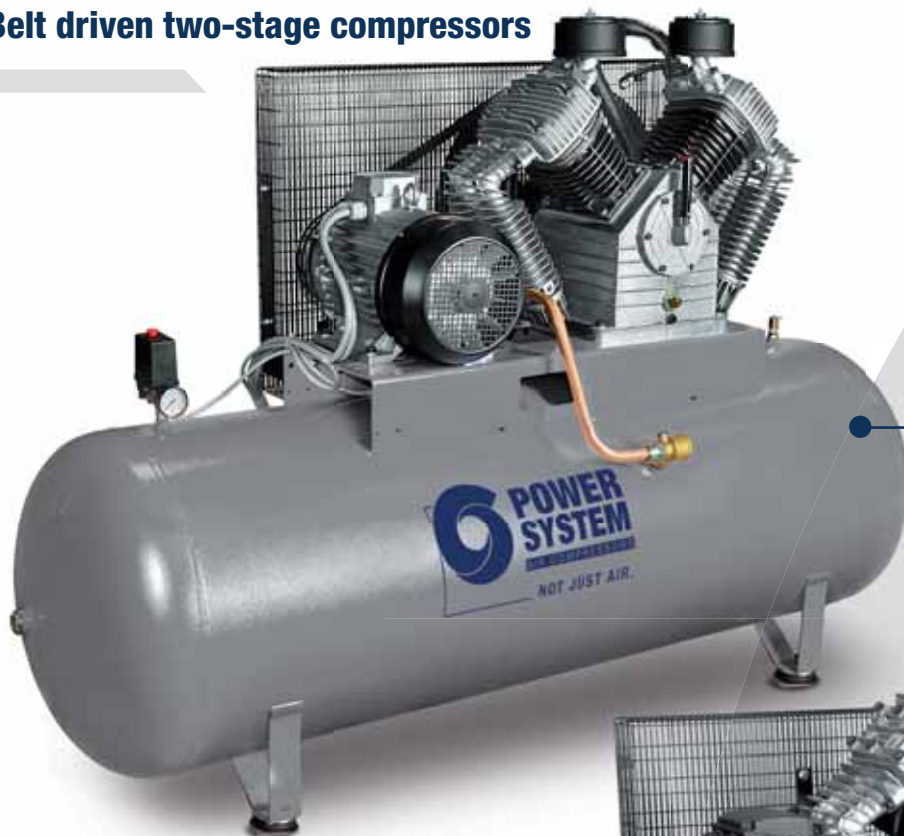

PS60/500 FT15 SD



PS100/500 FT20 SD



Avviamento stella-triangolo.
Star-delta starter.

Nome Name	Codice Code	Gruppo Pump	Serbatoio Tank		Potenza Power		Cilindri Cylinder		Press. Max Max press.		N° Giri RPM	Aria aspirata Air displacement		Volt/Hz	Peso lordo Gross weight		Dimensioni imballo Box dimensions	Codice a barre Ean code
			L	Hp	kW	n.	bar	PSI	l/min.	CFM		kg	Lbs		LxPxAx WxDxH			
PS60/500 FT15 SD	SNTNA05PWS074	PS60	500	15	11	4V	11	160	1200	1745	61,5	400/50	350	771,6	2270x860x1660	8016738759631		
PS100/500 FT20 SD	SPTNB05PWS075	PS100	500	20	15	4V	11	160	1000	2148	75,7	400/50	416	917,1	2270x860x1660	8016738759648		
PS60/900 FT15 SD	SNRNA05PWS076	PS60	900	15	11	4V	11	160	1200	1745	61,5	400/50	450	992,1	2310x910x1820	8016738759655		
PS100/900 FT20 SD	SPRNB05PWS077	PS100	900	20	15	4V	11	160	1000	2148	75,7	400/50	516	1137,6	2310x910x1820	8016738759662		



NOT JUST AIR.

PLUS LINE

Compressori serie Twin Tank Twin Tank compressors



Comodo nello spostamento, pratico per appoggiarci gli attrezzi, protetto contro involontari urti.

Il tuo migliore assistente.

*Easy in moving it around, smart to lean tools on it, protected against involuntary hits.
Your best heavy duty assistant.*



PS17/17+17 CM3



Nome Name	Codice Code	Gruppo Pump	Serbatoio Tank		Potenza Power		Cilindri Cylinder		Press. Max Max press.		N° Giri RPM	Aria aspirata Air displacement		Volt/Hz	Peso lordo Gross weight		Dimensioni imballo Box dimensions	Codice a barre Ean code
			L	Hp	kW	n.	bar	PSI	l/min.	CFM		kg	Lbs		LxPxAx WxDxH			
PS17/17+17 CM3	SZZC504PWS133	PS17	17+17	3	2,2	2	10	145	1250	400	14,1	230/50	76,3	168,2	940x770x1150	8016738793185		
PS17/17+17 CT3	SZZC541PWS134	PS17	17+17	3	2,2	2	10	145	1250	400	14,1	400/50	76,3	168,2	940x770x1150	8016738793192		
PS25/17+17 CT4	SGZC601PWS135	PS25	17+17	4	3	2	11	160	1200	495	17,4	400/50	81,3	179,2	940x770x1150	8016738793208		
PS28/17+17 CT5,5	SHZC701PWS136	PS28	17+17	5,5	4	2	11	160	1290	662	23,3	400/50	84,3	185,8	940x770x1150	8016738793215		

PLUS LINE

Compressori Verticali Vertical compressors

A completamento della gamma Plus Line è stata inserita la serie "verticale", utile per chi ha problemi di spazio.

The Plus Line range is completed by the "vertical" series, a space saving solution.

PS30/270 FTV7,5



PS2800B/100 CMV3



Nome Name	Codice Code	Gruppo Pump	Serbatoio Tank		Potenza Power		Cilindri Cylinder	Press. Max Max press.		N° Giri RPM	Aria aspirata Air displacement		Volt/Hz	Peso lordo Gross weight		Dimensioni imballo Box dimensions		Codice a barre Ean code
			L	Hp	kW	n.		bar	PSI		l/min.	CFM		kg	Lbs	LxPxX WxDxH		
PS2800B/100 CMV3	28FY504PWS246	PS2800B	100	3	2,2	2	10	145	1570	330	11,6	230/50	78	172	650x630x1320	8016738815238		
PS3800B/150 FMV3	36HY504PWS082	PS3800B	150	3	2,2	2	10	145	1100	390	13,7	230/50	127	280,0	760x600x1980	8016738764680		
PS18C/150 FTV3	SEHY541PWS137	PS18C	150	3	2,2	2	10	145	900	343	12,1	400/50	115	253,5	860x850x2000	8016738793222		
PS25/270 FTV5,5	SGNY701PWS138	PS25	270	5,5	4	2	11	160	1184	612	21,6	400/50	160	352,7	860x850x2000	8016738793239		
PS30/270 FTV5,5	SLNY701PWS139	PS30	270	5,5	4	2	11	160	1000	727	25,6	400/50	183	403,4	860x850x2000	8016738793246		
PS30/270 FTV7,5	SLNY801PWS140	PS30	270	7,5	5,5	2	11	160	1200	872	30,7	400/50	190	418,9	860x850x2000	8016738793253		

PLUS LINE

Compressori Tandem Tandem compressors

La gamma Tandem garantisce altissime prestazioni grazie alla doppia portata e ad un alto rendimento volumetrico.

The Tandem range delivers exceptionally high performance thanks to its dual capacity/intake and high volumetric efficiency.



PS50/900TD FT10+10 SD



Avviamento stella-triangolo.
Star-delta starter.

Nome Name	Codice Code	Gruppo Pump	Serbatoio Tank		Potenza Power		Cilindri Cylinder	Press. Max Max press.		N° Giri RPM	Aria aspirata Air displacement		Volt/Hz	Peso lordo Gross weight		Dimensioni imballo Box dimensions		Codice a barre Ean code
			L	Hp	kW	n.		bar	PSI		l/min.	CFM		kg	Lbs	LxPxA	WxDxH	
PS25/500TD FT4+4	SGUN601PWS141	PS25	500	4+4	3+3	2	11	160	1200	990	34,9	400/50	260	573,2	2010x650x1330	8016738793260		
PS28/500TD FT5,5+5,5	SHUN701PWS142	PS28	500	5,5+5,5	4+4	2	11	160	1290	1324	46,6	400/50	275	606,3	2010x650x1330	8016738793277		
PS28/500TD FT5,5+5,5 SD	SHUN705PWS143	PS28	500	5,5+5,5	4+4	2	11	160	1290	1324	46,6	400/50	281	619,5	2010x650x1330	8016738793284		
PS30/500TD FT5,5+5,5	SLUN701PWS144	PS30	500	5,5+5,5	4+4	2	11	160	1000	1454	51,2	400/50	306	674,6	2010x650x1330	8016738793291		
PS30/500TD FT5,5+5,5 SD	SLUN705PWS145	PS30	500	5,5+5,5	4+4	2	11	160	1000	1454	51,2	400/50	316	696,7	2010x650x1330	8016738793307		
PS30/500TD FT7,5+7,5	SLUN801PWS146	PS30	500	7,5+7,5	5,5+5,5	2	11	160	1200	1744	61,4	400/50	320	705,5	2010x650x1330	8016738793314		
PS30/500TD FT7,5+7,5 SD	SLUN805PWS147	PS30	500	7,5+7,5	5,5+5,5	2	11	160	1200	1744	61,4	400/50	330	727,5	2010x650x1330	8016738793321		
PS50/500TD FT10+10	SMUN901PWS148	PS50	500	10+10	7,5+7,5	2	11	160	1000	2148	75,7	400/50	449	989,9	2270x860x1660	8016738793338		
PS50/500TD FT10+10 SD	SMUN905PWS149	PS50	500	10+10	7,5+7,5	2	11	160	1000	2148	75,7	400/50	459	1011,9	2270x860x1660	8016738793345		
PS30/900TD FT7,5+7,5	SLWN801PWS150	PS30	900	7,5+7,5	5,5+5,5	2	11	160	1200	1744	61,4	400/50	525	1157,4	2270x860x1660	8016738793352		
PS30/900TD FT7,5+7,5 SD	SLWN805PWS151	PS30	900	7,5+7,5	5,5+5,5	2	11	160	1200	1744	61,4	400/50	535	1179,5	2270x860x1660	8016738793369		
PS50/900TD FT10+10	SMWN901PWS152	PS50	900	10+10	7,5+7,5	2	11	160	1000	2148	75,7	400/50	598	1318,4	2270x860x1660	8016738793376		
PS50/900TD FT10+10 SD	SMWN905PWS153	PS50	900	10+10	7,5+7,5	2	11	160	1000	2148	75,7	400/50	608	1340,4	2270x860x1660	8016738793383		
PS60/900TD FT15+15 SD	SNWNA05PWS154	PS60	900	15+15	11+11	4V	11	160	1200	3490	122,9	400/50	673	1483,7	2310x910x1820	8016738793390		

SILVER LINE

Compressori a cinghia con serbatoio zincato
Belt driven compressors with galvanized tank

I punti di forza della gamma Strength points of the range

- Gruppi pompanti progettati per un servizio gravoso, di alte affidabilità e prestazioni.
- Serbatoio zincato per una sicura e duratura prevenzione contro la corrosione causata dalla condensazione dell'acqua al loro interno.
- Compressore dotato di spina di alimentazione CE 400 Volt con controllo fasi integrato per un avviamento senza rischi.

- 1 Filtro per l'abbattimento del rumore.
- 2 Prolunga per lo scarico dell'olio.
- 3 Ruote pivotanti con freno.
- 4 Filtro - regolatore a tazza: composto da scaricatore condensa e regolatore pressione. Contribuisce contemporaneamente a un'elevata pulizia dell'aria compressa in uscita e alla regolazione della sua pressione.

- *Heavy Duty service reciprocating piston pumps, strong and reliable, for a long service life.*
- *Galvanized tank for a safe and lasting prevention against corrosion caused by water condensation.*
- *Featuring EC 400 Volt power plug with Phase Control for a risk-less start-up.*

- 1 *Filter lowering noise level.*
- 2 *Extension for oil drain.*
- 3 *Pivoting wheels with brakes.*
- 4 *Pressure regulator with condensate drain: contributes at the same time to a high cleanliness of the output compressed air and to an optimum regulation of its pressure.*

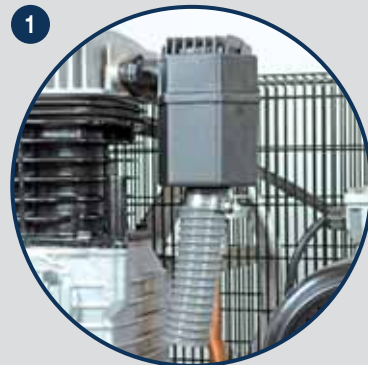

Nome Name	Codice Code	Gruppo Pump	Serbatoio Tank		Potenza Power		Cilindri Cylinder	Press. Max Max press.		N° Giri RPM	Aria aspirata Air displacement		Volt/Hz	Peso lordo Gross weight		Dimensioni imballo Box dimensions	Codice a barre Ean code
			L	Hp	kW	n.		bar	PSI		l/min.	CFM		kg	Lbs		
PS25/90G CT4	SGGC601PWS227	PS25	90	4	3	2	11	160	1200	495	17,4	400/50	90	198,4	1010x510x970	8016738794663	
PS28/90G CT5,5	SHGC701PWS228	PS28	90	5,5	4	2	11	160	1290	662	23,3	400/50	98	216,1	1010x510x970	8016738794670	
PS25/270G CT4	SGNC601PWS229	PS25	270	4	3	2	11	160	1200	495	17,4	400/50	143	315,3	1640x560x1190	8016738794687	
PS28/270G CT5,5	SHNC701PWS230	PS28	270	5,5	4	2	11	160	1290	662	23,3	400/50	153	337,3	1640x560x1330	8016738794694	
PS28/270G FT5,5	SHNN701PWS231	PS28	270	5,5	4	2	11	160	1290	662	23,3	400/50	153	337,3	1640x560x1330	8016738794700	
PS30/270G FT7,5	SLNN801PWS232	PS30	270	7,5	5,5	2	11	160	1200	872	30,7	400/50	171	377,0	1640x560x1330	8016738794717	

SILVER LINE

Compressori a cinghia con serbatoio zincato
Belt driven compressors with galvanized tank

“Lo Stato dell’Arte” nei compressori a pistoni professionali.
“The State of the Art” in professional piston compressors.

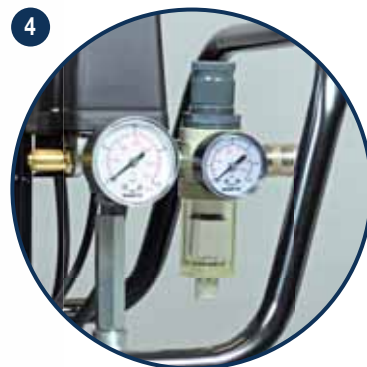

Nome Name	Codice Code	Gruppo Pump	Serbatoio Tank		Potenza Power		Cilindri Cylinder	Press. Max Max press.		N° Giri RPM	Aria aspirata Air displacement		Volt/Hz	Peso lordo Gross weight		Dimensioni imballo Box dimensions	Codice a barre Ean code
			L	Hp	kW	n.		bar	PSI		l/min.	CFM		kg	Lbs		
PS30/500G FT7,5	SLTN801PWS233	PS30	500	7,5	5,5	2	11	160	1200	872	30,7	400/50	240	529,1	2010x650x1330	8016738794724	
PS50/500G FT10	SMTN901PWS234	PS50	500	10	7,5	2	11	160	1000	1074	37,8	400/50	285	628,3	2270x860x1660	8016738794731	
PS60/500G FT15 SD	SNTNA05PWS235	PS60	500	15	11	2	11	160	1200	1745	61,5	400/50	350	771,6	2270x860x1660	8016738794748	
PS100/500G FT20 SD	SPTNB05PWS236	PS100	500	20	15	2	11	160	1000	2148	75,7	400/50	416	917,1	2270x860x1660	8016738794755	

CONTRACTOR LINE

Motocompressori a benzina e diesel
Petrol and diesel engine
compressors

La gamma dei motocompressori è adatta per tutti gli utilizzi dove non è possibile avere l'alimentazione elettrica. La combinazione di un gruppo potente ed affidabile con un serbatoio che offre una grande riserva di aria compressa rende questi compressori adatti per tutti gli accessori pneumatici, compresi quelli che richiedono alte portate.

Engine driven compressors suitable for all applications where the mains power supply is not available. The combination of a powerful and reliable pump unit with a tank offering a large reserve of compressed air makes these compressors suitable for all pneumatic accessories, including high flow demanding ones.



CONTRACTOR LINE

Motocompressori a benzina e diesel

Petrol and diesel engine compressors

PS236/9,5 4S HONDA



SHUTTLE PS236 HONDA



PS3800B/100 9S HONDA



Nome Name	Codice Code	Gruppo Pump	Serbatoio Tank		Potenza Power		Cilindri Cylinder	Press. Max Max press.		N° Giri RPM	Aria aspirata Air displacement		Peso lordo Gross weight		Dimensioni imballo Box dimensions	Codice a barre Ean code
			L	Hp	kW	n.		bar	PSI		l/min.	CFM	kg	Lbs		
Shuttle PS236 Honda	FMAA6P1PWS205	PS236	3,2	5	3,7	1	10	145	3400	235	8,3	29,2	64,4	540x420x510	8016738793901	
PS236/9,5 4S Honda	FMPP6P1PWS206	PS236	9,5	4	3	1	10	145	3400	235	8,3	39	86,0	520x420x780	8016738793918	
PS3800B/10+10 5,5S Honda	36BW7P1PWS207	PS3800B	10+10	5,5	4	1	10	145	1100	390	13,7	72	158,7	820x600x865	8016738793925	
PS3800B/100 5,5S Honda	36FC7P1PWS208	PS3800B	100	5,5	4	1	10	145	1100	390	13,7	109	240,3	1140x650x1200	8016738793932	
PS3800B/100 9S Honda	36FC8P1PWS209	PS3800B	100	9	6,7	1	10	145	1400	460	16,2	144	317,5	1140x650x1200	8016738793949	

CONTRACTOR LINE

Motocompressori a benzina e diesel

Petrol and diesel engine compressors



PS7/200 F9S HONDA



PS7/270 F10 DIESEL



Nome Name	Codice Code	Gruppo Pump	Serbatoio Tank	Potenza Power		Cilindri Cylinder	Press. Max Max press.		N° Giri RPM	Aria aspirata Air displacement		Peso lordo Gross weight		Dimensioni imballo Box dimensions	Codice a barre Ean code
			L	Hp	kW		n.	bar		PSI	l/min.	CFM	kg		
PS7/100 9S Honda	N7FC8P1PWS210	PS7	100	9	6,7	1	10	145	970	660	23,2	152	335,1	1140x650x1200	8016738793956
PS7/200 F9S Honda	N7LN8P1PWS211	PS7	200	9	6,7	1	10	145	970	660	23,2	183	403,4	1450x665x1330	8016738793963
PS7/270 F11S Honda	N7NN9P1PWS212	PS7	270	11	8,2	1	10	145	1400	945	33,3	188	414,5	1640x560x1330	8016738793970
PS7/270 F10 Diesel	N7NN9R1PWS213	PS7	270	10	7,5	1	10	145	1400	945	33,3	179	394,6	1640x560x1330	8016738793987
PS7/500 F10 Diesel	N7TN9R1PWS214	PS7	500	10	7,5	1	10	145	1400	945	33,3	289	637,1	2005x895x1660	8016738793994

SILENT LINE

Bassi livelli di rumorosità

Compressori silenziosi con il livello di rumorosità più basso della categoria.

Low noise levels

Quiet compressors with the lowest noise level available in the category.

La linea dei compressori Silenziati Power System si distingue per il progetto innovativo in termini di tecnologia e design. Realizzati per risolvere il problema del rumore negli ambienti di lavoro, questi compressori si distinguono sul mercato per il più basso livello di rumorosità della categoria. La riduzione della rumorosità è stata ottenuta racchiudendo la macchina in un mobile insonorizzato con speciali pannelli fonoassorbenti, curando la ventilazione e, su alcuni modelli, utilizzando speciali silenziatori di aspirazione. La combinazione di materiali di alta qualità e la massima accuratezza nell'assemblaggio della macchina assicurano ottime prestazioni e una lunga durata nel tempo.

The Power System Silent line excels thanks to its innovative design and advanced technology. Designed to solve noise issue on the workplace, this range stands out in its category for its low level noise emissions.

Noise mitigation is achieved by sealing the compressor in a soundproof cabinet fitted with sound-absorbing panels, giving special attention to ventilation and, for some models, using special air intake silencers. The combination of high-quality components and the scrupulous accuracy of the machine assembly ensures excellent performance and a long operative life-cycle.



Facile manutenzione

Queste macchine sono state progettate con particolare riguardo alla semplicità di manutenzione di tutti i componenti interni.

Easy maintenance

Designed with particular attention to user-friendly maintenance.

La gamma The range



2÷3 Hp
100÷200 L

4÷7,5 Hp
270 L

7,5÷10 Hp
500 L

2÷3 Hp
24 L

4÷10 Hp
3 L

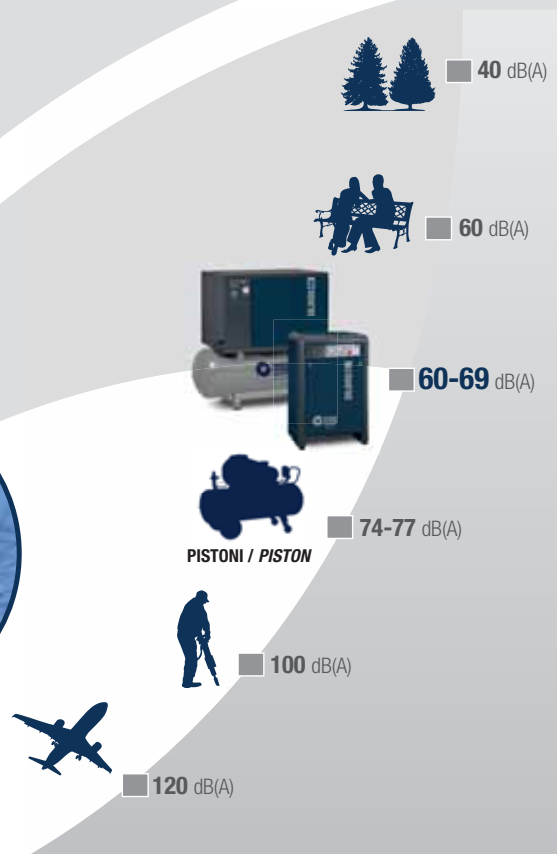

Design compatto
per un ridotto ingombro.

Compact design
space saving solution.

SILENT LINE



I punti di forza della gamma Strength points of the range

- elevato abbattimento del rumore;
- 1 ventilazione centrifuga forzata;
- 2 slitta tendicinghia che regola la tensione della cinghia;
- 3 pannello di controllo integrato;
- 4 gruppo pompante con cilindro in ghisa per una lunga durata;
- 4 collettore alettato per il raffreddamento dell'aria;
- 5 silenziatore di aspirazione supplementare (sui modelli da 4 a 10 Hp);
- avviamento stella-triangolo controllato da una scheda elettronica con segnali di allarme (sui modelli SILBOX 2 e SILBOX 3).

- *low noise emission;*
- 1 *forced ventilation;*
- 2 *belt tensioner skid adjusting belt tension;*
- 3 *integrated control panel;*
- 4 *pump with cast iron cylinder for long life;*
- 4 *air cooling finned aftercooler;*
- 5 *extra intake silencer (on 4 to 10 Hp models);*
- *star-delta starter run by electronic card with warning alarms (on SILBOX 2 and SILBOX 3 models).*

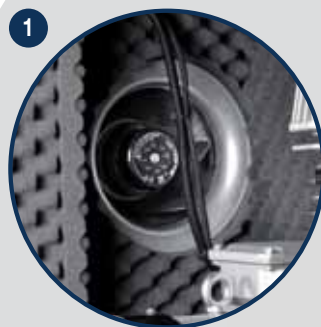

Nome Name	Codice Code	Gruppo Pump	Serbatoio Tank		Potenza Power		Cilindri Cylinder	Press. Max Max press.		N° Giri RPM	Aria aspirata Air displac.		Volt/Hz	Peso lordo Gross weight		Dimensioni imballo Box dimensions	dB(A)	Codice a barre Ean code
			L	Hp	kW	n.		bar	PSI		l/min.	CFM		kg	Lbs			
SILBOX 1 PS11/100 CM2	SCFR404PWS155	PS11	100	2	1,5	2	10	145	1180	260	9,2	230/50	87	191,8	1140x650x1200	68	8016738793406	
SILBOX 1 PS17/100 CM3	SZFR504PWS061	PS17	100	3	2,2	2	10	145	1250	400	14,1	230/50	93	205,0	1140x650x1200	68	8016738759303	
SILBOX 1 PS17/100 CT3	SZFR541PWS062	PS17	100	3	2,2	2	10	145	1250	400	14,1	400/50	94	207,2	1140x650x1200	68	8016738759310	
SILBOX 1 PS17/200 CM3	SZLR504PWS156	PS17	200	3	2,2	2	10	145	1250	400	14,1	230/50	127	280,0	1450x665x1330	68	8016738793413	
SILBOX 1 PS17/200 FM3	SZLT504PWS157	PS17	200	3	2,2	2	10	145	1250	400	14,1	230/50	127	280,0	1450x665x1330	68	8016738793420	
SILBOX 1 PS17/200 CT3	SZLR541PWS158	PS17	200	3	2,2	2	10	145	1250	400	14,1	400/50	127	280,0	1450x665x1330	68	8016738793437	
SILBOX 1 PS17/200 FT3	SZLT541PWS159	PS17	200	3	2,2	2	10	145	1250	400	14,1	400/50	127	280,0	1450x665x1330	68	8016738793444	

SILENT LINE

Gamma SILBOX 1 - 2
SILBOX 1 - 2 range

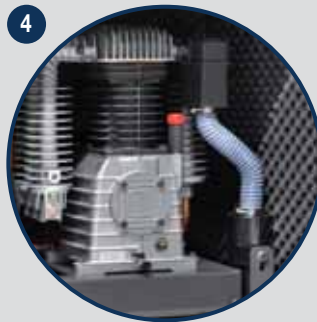

SILBOX 1 PS17/100 CM3



SILBOX 2 PS28/270 FT5,5



Nome Name	Codice Code	Gruppo Pump	Serbatoio Tank	Potenza Power		Cilindri Cylinder	Press. Max Max press.		N° Giri RPM	Aria aspirata Air displac.		Volt/Hz	Peso lordo Gross weight		Dimensioni imballo Box dimensions	dB(A)	Codice a barre Ean code
			L	Hp	kW		bar	PSI		l/min.	CFM		kg	Lbs			
SILBOX 2 PS25/270 FT4	SGNT601PWS160	PS25	270	4	3	2	11	160	1200	495	17,4	400/50	249	548,9	1550x765x1505	68	8016738793451
SILBOX 2 PS28/270 FT5,5	SHNT701PWS161	PS28	270	5,5	4	2	11	160	1290	662	23,4	400/50	258	568,8	1550x765x1505	68	8016738793468
SILBOX 2 PS28/270 FT5,5 SD	SHNT705PWS162	PS28	270	5,5	4	2	11	160	1290	662	23,3	400/50	264	582,0	1550x765x1505	68	8016738793475
SILBOX 2 PS30/270 FT7,5	SLNT801PWS164	PS30	270	7,5	5,5	2	11	160	1200	872	30,7	400/50	277	610,7	1550x765x1505	68	8016738793482

SILENT LINE

Gamma SILBOX 3

SILBOX 3 range

1 Per i modelli con avviamento stella triangolo il pannello di controllo è dotato di centralina elettronica con 3 spie di segnalazione: compressore sotto tensione, compressore in funzione e allarme alta temperatura.

For models with star-delta starting, the control panel is equipped with an electronic control unit with 3 leds: compressor powered, compressor running and high temperature alarm.



SILBOX 3 PS30/500 FT7,5



Disponibili le versioni con essiccatore per i modelli con serbatoi da 500 litri.

Refrigeration dryer available on models with 500-litre tank.

Nome Name	Codice Code	Gruppo Pump	Serbatoio Tank		Potenza Power		Cilindri Cylinder		Press. Max Max press.		N° Giri RPM	Aria aspirata Air displac.		Volt/Hz	Peso lordo Gross weight		Dimensioni imballo Box dimensions		dB(A)	Codice a barre Ean code
			L	Hp	kW	n.	bar	PSI	l/min.	CFM		kg	Lbs		LxPxH	WxDxH				
SILBOX 3 PS30/500 FT7,5	SLTT801PWS300	PS30	500	7,5	5,5	2	11	160	1200	872	30,7	400/50	360	793,7	2005x970x1660	69	8016738793499			
SILBOX 3 PS30/500 FT7,5 SD	SLTT805PWS302	PS30	500	7,5	5,5	2	11	160	1200	872	30,7	400/50	370	815,7	2005x970x1660	69	8016738793505			
SILBOX 3 PS50/500 FT10	SMTT901PWS306	PS50	500	10	7,5	2	11	160	1000	1074	37,8	400/50	403	888,5	2005x970x1660	69	8016738793512			
SILBOX 3 PS50/500 FT10 SD	SMTT905PWS308	PS50	500	10	7,5	2	11	160	1000	1074	37,8	400/50	413	910,5	2005x970x1660	69	8016738793529			
Con essiccatore With dryer																				
SILBOX 3 PS30/500 FT7,5+ESS	SLTT801PWS301	PS30	500	7,5	5,5	2	11	160	1200	872	30,7	400/50	387	853,2	2005x970x1660	69	8016738793536			
SILBOX 3 PS30/500 FT7,5 SD+ESS	SLTT805PWS303	PS30	500	7,5	5,5	2	11	160	1200	872	30,7	400/50	397	875,2	2005x970x1660	69	8016738793543			
SILBOX 3 PS50/500 FT10+ESS	SMTT901PWS307	PS50	500	10	7,5	2	11	160	1000	1074	37,8	400/50	430	948,0	2005x970x1660	69	8016738793550			
SILBOX 3 PS50/500 FT10 SD+ESS	SMTT905PWS309	PS50	500	10	7,5	2	11	160	1000	1074	37,8	400/50	440	970,0	2005x970x1660	69	8016738793567			
Alta pressione High pressure																				
SILBOX 3 PS30/500 FT7,5 SD AP	SLTT805PWS304	PS30	500	7,5	5,5	2	14	203	900	660	23,2	400/50	408	899,5	2005x970x1660	69	8016738793574			
SILBOX 3 PS50 FT10 SD AP	SMAT905PWS305	PS50	-	10	7,5	2	14	203	950	1000	35,2	400/50	256	564,4	1290x940x1040	69	8016738793581			

SILENT LINE

Gamma SILBOX-PRO

SILBOX-PRO range



Macchine compatte, robuste e costruite per durare nel tempo, adatte per essere posizionate vicino all'applicazione perchè estremamente silenziose.

I punti di forza di questi modelli:

- 1 Comandi centralizzati nel pannello di controllo.
- 2 Silenziatore di aspirazione supplementare.
- 3 La struttura della base consente una agevole trasportabilità della macchina con traspallet o muletto.
- 4 Serbatoio incorporato da 24 litri.

Compact, built to last and extremely silent, allowing their installation next to the workplace.

Strength points of these models:

- 1 Commands grouped in control panel.
- 2 Additional air intake silencer.
- 3 Base designed for easy transport by forklift or pallet jack.
- 4 Integrated 24-litre tank.



Rumorosità posizionata ai più bassi livelli del settore.

Noise level positioned at the lowest of the category's standards.



SILBOX-PRO 11 M2



Nome Name	Codice Code	Gruppo Pump	Serbatoio Tank		Potenza Power		Cilindri Cylinder		Press. Max Max press.		N° Giri RPM	Aria aspirata Air displac.		Volt/Hz	Peso lordo Gross weight		Dimensioni imballo Box dimensions		dB(A)	Codice a barre Ean code
			L	Hp	kW	n.	bar	PSI	l/min.	CFM		kg	Lbs		LxPxH	WxDxH				
SILBOX-PRO 11 M2	SCOM404PWS063	PS11	24	2	1,5	2	10	145	1180	260	9,2	230/50	111	244,7	720x640x1250	60	8016738759327			
SILBOX-PRO 11 T2	SCOM441PWS064	PS11	24	2	1,5	2	10	145	1180	260	9,2	400/50	112	246,9	720x640x1250	60	8016738759334			
SILBOX-PRO 17 M3	SZOM504PWS174	PS17	24	3	2,2	2	10	145	1250	400	14,1	230/50	120	264,6	720x640x1250	63	8016738793598			
SILBOX-PRO 17 T3	SZOM541PWS175	PS17	24	3	2,2	2	10	145	1250	400	14,1	400/50	121	266,8	720x640x1250	63	8016738793604			

SILENT LINE

Gamma SILBOX-PRO
SILBOX-PRO range



Rumorosità posizionata
ai più bassi livelli del settore.
*Noise level positioned
at the lowest of the
category's standards.*

I punti di forza di questi modelli:

- 1 Pannello di controllo con scheda elettronica di autodiagnosi.
- 2 Ventilazione forzata termostata per l'abbattimento della temperatura interna.
- 3 Silenziatore di aspirazione supplementare.
- 4 Serbatoio smorzatore di pulsazioni con scarico condensa.

Strength points of these models:

- 1 Control panel with electronic self-diagnosis.
- 2 Thermostatically forced ventilation to reduce internal temperature.
- 3 Additional air intake silencer.
- 4 Anti-pulsator tank with condensate drain.



SILBOX-PRO 30 T5,5



Nome Name	Codice Code	Gruppo Pump	Serbatoio Tank		Potenza Power		Cilindri Cylinder		Press. Max Max press.		N° Giri RPM	Aria aspirata Air displac.		Volt/Hz	Peso lordo Gross weight		Dimensioni imballo Box dimensions		dB(A)	Codice a barre Ean code
			L	Hp	kW	n.	bar	PSI	l/min.	CFM		kg	Lbs		LxPxH	WxDxH				
SILBOX-PRO 25 T4	SGOM601PWS065	PS25	3	4	3	2	11	160	1200	495	17,4	400/50	157	346,1	870x640x1250	65	8016738759341			
SILBOX-PRO 25 T4 SD	SGOM605PWS176	PS25	3	4	3	2	11	160	1200	495	17,4	400/50	162	357,1	870x640x1250	65	8016738793611			
SILBOX-PRO 30 T5,5	SLOM701PWS066	PS30	3	5,5	4	2	11	160	1000	727	25,6	400/50	178	392,4	870x640x1250	65	8016738759358			
SILBOX-PRO 30 T5,5 SD	SLOM705PWS067	PS30	3	5,5	4	2	11	160	1000	727	25,6	400/50	183	403,4	870x640x1250	65	8016738759365			
SILBOX-PRO 30 T7,5	SLOM801PWS068	PS30	3	7,5	5,5	2	11	160	1200	872	30,7	400/50	190	418,9	870x640x1250	65	8016738759372			
SILBOX-PRO 30 T7,5 SD	SLOM805PWS069	PS30	3	7,5	5,5	2	11	160	1200	872	30,7	400/50	195	429,9	870x640x1250	68	8016738759389			
SILBOX-PRO 50 T10	SMOM901PWS070	PS50	3	10	7,5	2	11	160	1000	1074	37,8	400/50	228	502,6	870x640x1250	68	8016738759396			
SILBOX-PRO 50 T10 SD	SMOM905PWS071	PS50	3	10	7,5	2	11	160	1000	1074	37,8	400/50	233	513,7	870x640x1250	68	8016738759402			

Alta pressione | High pressure

SILBOX-PRO 25 AP T4	SGOM601PWS177	PS25	3	4	3	2	13	189	1015	420	14,8	400/50	157	346,1	870x640x1250	65	8016738793628
SILBOX-PRO 25 AP T4 SD	SGOM605PWS178	PS25	3	4	3	2	13	189	1015	420	14,8	400/50	162	357,1	870x640x1250	65	8016738793635
SILBOX-PRO 30 AP T5,5	SLOM701PWS179	PS30	3	5,5	4	2	13	189	785	570	20,1	400/50	178	392,4	870x640x1250	65	8016738793642
SILBOX-PRO 30 AP T5,5 SD	SLOM705PWS180	PS30	3	5,5	4	2	13	189	785	570	20,1	400/50	183	403,4	870x640x1250	65	8016738793659
SILBOX-PRO 30 AP T7,5	SLOM801PWS181	PS30	3	7,5	5,5	2	13	189	900	660	23,2	400/50	190	418,9	870x640x1250	65	8016738793666
SILBOX-PRO 30 AP T7,5 SD	SLOM805PWS182	PS30	3	7,5	5,5	2	13	189	900	660	23,2	400/50	195	429,9	870x640x1250	65	8016738793673
SILBOX-PRO 50 AP T10	SMOM901PWS183	PS50	3	10	7,5	2	13	189	800	857	30,2	400/50	228	502,6	870x640x1250	68	8016738793680
SILBOX-PRO 50 AP T10 SD	SMOM905PWS184	PS50	3	10	7,5	2	13	189	800	857	30,2	400/50	233	513,7	870x640x1250	68	8016738793697

BASIC LINE

Compressori a cinghia monostadio Belt driven single-stage compressors

Questa gamma si compone di **compressori a cinghia monostadio**, costruiti per garantire, grazie alla ridotta velocità di rotazione dei gruppi pompanti, affidabilità e durata nel tempo. Adatti ad un impiego gravoso e continuato, sono lo strumento di lavoro ideale per hobbisti esigenti, professionisti e piccole imprese.

*This range is made up of the **belt driven single-stage compressors**, built to ensure reliability and long life thanks to the reduced rotation speed of the pump. Suitable for constant hard work, these are ideal work tools for demanding hobbyists, professionals and small enterprises.*



BASIC LINE

Compressori a cinghia monostadio
Belt driven single-stage compressors



PS2800/50 CM2



Nome Name	Codice Code	Gruppo Pump	Serbatoio Tank		Potenza Power		Cilindri Cylinder		Press. Max Max press.		N° Giri RPM	Aria aspirata Air displacement		Volt/Hz	Peso lordo Gross weight		Dimensioni imballo Box dimensions		Codice a barre Ean code
			L	Hp	kW	n.	bar	PSI	l/min.	CFM		kg	Lbs		LxPxAX	WxDxH			
PS2800/30 CM2	28CC404PWS248	PS2800	30	2	1,5	2	10	145	1250	255	9,0	230/50	45	99,2	820x390x750	8016738793703			
PS2800/50 CM2	28DC404PWS186	PS2800	50	2	1,5	2	10	145	1250	255	9,0	230/50	49,5	109,1	820x390x750	8016738793710			
PS2800/50 CT2	28DC441PWS187	PS2800	50	2	1,5	2	10	145	1250	255	9,0	400/50	50,5	111,3	820x390x750	8016738793727			
PS2800/100 CM2	28FC404PWS188	PS2800	100	2	1,5	2	10	145	1250	255	9,0	230/50	61	134,5	1025x435x845	8016738793734			
PS2800/100 CT2	28FC441PWS189	PS2800	100	2	1,5	2	10	145	1250	255	9,0	400/50	62	136,7	1025x435x845	8016738793741			
PS2800B/100 CM3	28FC504PWS190	PS2800B	100	3	2,2	2	10	145	1570	330	11,6	230/50	63	138,9	1025x435x845	8016738793758			
PS2800B/100 CT3	28FC541PWS191	PS2800B	100	3	2,2	2	10	145	1570	330	11,6	400/50	64	141,1	1025x435x845	8016738793765			
PS2800/150 CM2	28HC404PWS192	PS2800	150	2	1,5	2	10	145	1250	255	9,0	230/50	83	183,0	1310x430x1030	8016738793772			
PS2800/150 CT2	28HC441PWS193	PS2800	150	2	1,5	2	10	145	1250	255	9,0	400/50	84	185,2	1310x430x1030	8016738793789			
PS2800B/150 CM3	28HC504PWS194	PS2800B	150	3	2,2	2	10	145	1570	330	11,6	230/50	87	191,8	1310x430x1030	8016738793796			
PS2800B/150 CT3	28HC541PWS195	PS2800B	150	3	2,2	2	10	145	1570	330	11,6	400/50	85	187,4	1310x430x1030	8016738793802			
PS3800B/150 CM3	36HC504PWS196	PS3800B	150	3	2,2	2	10	145	1100	390	13,7	230/50	90	198,4	1310x430x1030	8016738793819			
PS3800B/150 CT3	36HC541PWS197	PS3800B	150	3	2,2	2	10	145	1100	390	13,7	400/50	91	200,6	1310x430x1030	8016738793826			

BASIC LINE

Compressori a cinghia monostadio
Belt driven single-stage compressors



PS3800B/200 CT4



Nome Name	Codice Code	Gruppo Pump	Serbatoio Tank	Potenza Power		Cilindri Cylinder	Press. Max Max press.		N° Giri RPM	Aria aspirata Air displacement		Volt/Hz	Peso lordo Gross weight		Dimensioni imballo Box dimensions	Codice a barre Ean code
				L	Hp		kW	n.		bar	PSI		l/min.	CFM		
PS2800B/200 CM3	28LC504PWS198	PS2800B	200	3	2,2	2	10	145	1570	330	11,6	230/50	111	244,7	1435x475x1125	8016738793833
PS2800B/200 CT3	28LC541PWS199	PS2800B	200	3	2,2	2	10	145	1570	330	11,6	400/50	109	240,3	1435x475x1125	8016738793840
PS3800B/200 CM3	36LC504PWS200	PS3800B	200	3	2,2	2	10	145	1100	390	13,7	230/50	113	249,1	1435x475x1125	8016738793857
PS3800B/200 CT3	36LC541PWS202	PS3800B	200	3	2,2	2	10	145	1100	390	13,7	400/50	118	260,1	1435x475x1125	8016738793871
PS3800B/200 CT4	36LC601PWS201	PS3800B	200	4	3	2	10	145	1400	480	16,9	400/50	121	266,8	1435x475x1125	8016738793864
PS3800B/270 CT4	36NC601PWS203	PS3800B	270	4	3	2	10	145	1400	480	16,9	400/50	142	313,1	1640x560x1190	8016738793888
PS3800B/270 FT4	36NN601PWS204	PS3800B	270	4	3	2	10	145	1400	480	16,9	400/50	142	313,1	1640x560x1190	8016738793895

BASI SADDLES

Basi fisse Base plate compressors

Compatte stazioni per la produzione dell'aria compressa, interamente equipaggiate e totalmente indipendenti. Queste macchine consentono di comporre impianti modulari e su richiesta possono essere dotati di centralina di avviamento.

Compact compressed air stations which are fully equipped and totally independent. These machines allow you to compose modular systems and they can also be equipped with start-up control panel, upon request.



PS50/BF10 SD



Avviamento stella-triangolo.
Star-delta starter.

Nome Name	Codice Code	Gruppo Pump	Serbatoio Tank		Potenza Power		Cilindri Cylinder		Press. Max Max press.		N° Giri RPM	Aria aspirata Air displacement		Volt/Hz	Peso lordo Gross weight		Dimensioni imballo Box dimensions	Codice a barre Ean code
			L	Hp	kW	n.	bar	PSI	l/min.	CFM		kg	Lbs		LxPxH WxDxH			
PS28/BF5,5	SHYN701PWS215	PS28	3	5,5	4	2	11	160	1290	662	23,3	400/50	92	202,8	990x850x1060	8016738794007		
PS30/BF5,5	SLYN701PWS216	PS30	3	5,5	4	2	11	160	1000	727	25,6	400/50	104	229,3	990x850x1060	8016738794014		
PS30/BF7,5	SLYN801PWS217	PS30	3	7,5	5,5	2	11	160	1200	872	30,7	400/50	109	240,3	990x850x1060	8016738794021		
PS30/BF7,5 SD	SLYN805PWS218	PS30	3	7,5	5,5	2	11	160	1200	872	30,7	400/50	115	253,5	990x850x1060	8016738794038		
PS50/BF10	SMYN901PWS219	PS50	3	10	7,5	2	11	160	1000	1074	37,8	400/50	154	339,5	1350x860x1050	8016738794045		
PS50/BF10 SD	SMYN905PWS220	PS50	3	10	7,5	2	11	160	1000	1074	37,8	400/50	160	352,7	1350x860x1050	8016738794052		
PS60/BF15	SNYNA01PWS221	PS60	3	15	11	4V	11	160	1200	1745	61,5	400/50	201	443,1	1350x860x1050	8016738794069		
PS60/BF15 SD	SNYNA05PWS222	PS60	3	15	11	4V	11	160	1200	1745	61,5	400/50	207	456,4	1350x860x1050	8016738794076		
PS100/BF20 SD	SPYNB05PWS224	PS100	3	20	15	4V	11	160	1000	2148	75,7	400/50	264	582,0	1350x860x1050	8016738794090		

CUSTOMER CARE



Oltre a prodotti di elevata qualità e contenuto tecnologico, POWER SYSTEM offre un servizio attento alle esigenze del cliente. Il primo obiettivo è garantire un completo supporto tecnico e commerciale, identificando le esigenze e proponendo le soluzioni più idonee a soddisfarle, mantenendo nel tempo un rapporto di collaborazione e fiducia. POWER SYSTEM dispone di un team competente e motivato in grado di fornire diversi tipi di supporto: help desk telefonico, consulenza tecnica on-site, preventivi personalizzati, progetti chiavi in mano, programmi di manutenzione, corsi di aggiornamento, ecc.

Besides manufacturing products of the highest quality and technological content, POWER SYSTEM offers its customers an assistance service to meet their demands.

The first objective is to guarantee an allround technical and marketing support, identifying their needs and offering the most suitable solutions, nurturing a relation of mutual cooperation and trust over time.

POWER SYSTEM has a skilled and motivated team that can provide several services: a call center help-desk, technical on-site consultation, customized price quotes, turnkey projects, maintenance plans, technical update courses, etc.



Codice Code	Prodotto Product
#600000019	Olio sintetico/Synthetic oil Latta/Canister 1 L
#600000010	Olio sintetico/Synthetic oil Latta/Canister 1 L - 20 pcs.
122014XCMR	Olio minerale/Mineral oil Bottiglia/Bottle 1 L



MPK - Kit per manutenzione compressori a pistone MPK - Maintenance kit for piston compressors

I kit MPK sono stati appositamente studiati per i compressori a pistone POWER SYSTEM, per eseguire una manutenzione mirata e senza errori, facilitando l'individuazione degli esatti componenti da sostituire, essendo comprensivi di tutto il materiale necessario allo specifico intervento.

MPK kits are specifically designed to carry out preventive and error-free maintenance on POWER SYSTEM piston compressors, making it easy to identify the exact components to replace, being inclusive of all materials required for each maintenance service operation.

Utilizzate solo i lubrificanti consigliati Use only the recommended lubricants

L'utilizzo di lubrificanti scadenti può causare danni irreversibili al compressore e spese impreviste per manutenzione e riparazione.

The use of low-quality lubricants may cause the irreparable damage to the compressor or lead to unforeseen repair and maintenance costs.



I modelli e le caratteristiche in questo catalogo possono essere soggetti a modifiche senza preavviso.
The models and characteristics in this catalogue may be subject to change without notice.

FNA S.p.A. Via Einaudi, 6
10070 Robassomero Torino ITALY
T: +39 011 92 33 000 F: +39 011 92 41 138

BOLOGNA PLANT:
Via Toscana, 21 40069 Zola Predosa Bologna ITALY
T: +39 051 61 68 111 F: +39 051 75 24 08
info@fnacompressors.com
www.fnacompressors.com



a brand of



AUTHORIZED DISTRIBUTOR:

Follow us on: [LinkedIn](#)



powersystem.it

